

TAKAGI-SUGENO FUZZY PARALLEL DISTRIBUTION COMPENSATION BASED THREE-AREA LFC DESIGN

H.A. Shayanfar¹ H. Shayeghi² A. Jalili³

1. Department of Electrical Engineering, South Tehran Branch, Islamic Azad University, Tehran, Iran, hashayanfar@yahoo.com

2. Technical Engineering Department, University of Mohaghegh Ardabili, Ardabil, Iran, hshayeghi@gmail.com

3. Electrical Engineering Department, Ardabil Branch, Islamic Azad University, Ardabil, Iran, arefjalili@gmail.com

Abstract- In this paper, a robust Takagi-Sugeno Fuzzy Parallel Distribution Compensation (TSFPDC) technique is proposed for the solution of Load Frequency Control (LFC) problem in the interconnected power system. In this strategy, control signal is tuned online from the knowledge base and the fuzzy inference which request fewer sources. In order to minimize the efforts of load disturbances and achieve the desired level of robust performance in the presence of modeling uncertainties and load changes, the idea of TSFPDC technique is being used for the solution of LFC problem. With the newly proposed method a simple and natural procedure is developed to handle the nonlinear control system. Only local variables are adopted as the input signals of each controller for the control design. Thus, the structure of the designed TSFPDC based LFC is simple and easy to implement. The effectiveness of the proposed method is demonstrated on a three-area interconnected power system with different condition under wide range of parametric uncertainties in comparison with the modified chaotic ant swarm optimization and bacterial foraging optimization based fuzzy type PID controllers through simulation results and some system performance indices. Results evaluation show that the proposed control strategy achieves good robust performance for wide range of system parameters and load changes in the presence of system nonlinearities and is superior to the other controllers. Moreover, this newly developed control strategy has simple structure and does not require an accurate model of the plant and fairly easy to implement which can be useful for the real world complex power system.

Keywords: LFC, Takagi-Sugeno Fuzzy Parallel Distribution Compensation, Power System Control, PID.

I. INTRODUCTION

Load Frequency Control (LFC) is one of the most importance issues in electric power system design and operation. The objective of the LFC in an interconnected power system is to maintain the frequency of each area and to keep tie-line power near to the scheduled values by

adjusting the MW outputs of the LFC generators so as to accommodate fluctuating load demands. The LFC problem has been dealt with extensively for more than four decades. A comprehensive literatures review about the earlier studied in the field of LFC problem has been presented by Shayeghi et. al [1]. The availability of an accurate model of the system under study plays a crucial role in the development of the most control strategies like optimal control [2-3]. However, an industrial process, such as a power system, contains different kinds of uncertainties due to changes in the system parameters and characteristics, loads variation and errors in the modeling. On the other hand, the operating points of a power system may change very much randomly during a daily cycle. Because of this, a fixed controller based on classical theory is certainly not suitable for the solution of LFC problem. Thus, some authors have suggested variable structure [4] and neural networks methods [5] for dealing with parameter variations. However, all the proposed methods are based on state-space approach and require information about the system states, which are not usually known or available. Lately, various adaptive techniques [6-7] have been introduced for LFC controller design. Due to requirement of the perfect model, which has to track the state variables and satisfy system constraints, it is rather difficult to apply these adaptive control techniques to LFC in practical implementations.

Recently, several authors have been applied robust control methodologies [8-10] for solution of the LFC problem. Although via these methods, the uncertainties are directly introduced to the synthesis. But models of large scalar power system have several features that preclude direct application of robust control methodologies. Among these properties, the most prominent are: very large (and unknown) model order, uncertain connection between subsystems, broad parameter variation and elaborate organizational structure. The stability issue of the fuzzy control systems has been extensively investigated. However, in many practical systems, there always exist uncertainties, which are frequently a source of instability. Thus, the robust fuzzy stabilization problem for uncertain nonlinear

systems has received considerable interest [11-12]. In this paper, in order to overcome these drawbacks a novel robust Takagi-Sugeno Fuzzy Parallel Distributed Compensation (TSFPDC) technique base on PID controller is proposed for the LFC problem solution. The past few years have witnessed rapidly growing interest in the fuzzy control of nonlinear systems. In particular, the so-called Takagi-Sugeno (T-S) fuzzy model has been widely employed for the control design of nonlinear systems, since it can combine the merits of both fuzzy logic theory and linear system theory [13].

Fuzzy logic theory enables us to utilize qualitative, linguistic information about a complex nonlinear system to decompose the task of the modeling and control design into a group of easier local tasks. At the same time, it also provides the mechanism to blend these local tasks together to yield the overall model and control design. On the other hand, advances in the linear system theory have made a large number of powerful design tools available. As a result, based on the linear T-S fuzzy model, the fruitful linear system theory can be applied to the analysis and controller synthesis of the nonlinear system [14]. Although the fuzzy controller is constructed using the local design structure, the feedback gains should be determined using the global design conditions. The global design conditions are needed to guarantee the global stability and control performance.

In general, for the simplicity of the practical implementation of the controllers, PID control with feedback signals available at the location of each controlled device is most favorable for the LFC problem [15-16]. A major problem plaguing the effective use of this method is the difficulty of accurately and automatically tuning the gains of PID controller. Because, it is a computationally expensive combinational optimization problem and also extraction of an appropriate set of static gains for all subsystem may be tedious, time consuming and process specific. In order to overcome these drawbacks, Particle Swarm Optimization (PSO) technique is used for the optimal tuning of the PID gains in each control area to improve the optimization synthesis and the speed of the algorithms convergence in this paper. PSO is a novel population based meta-heuristic, which utilizes the swarm intelligence generated by the cooperation and competition between the particle in a swarm and has emerged as a useful tool for the engineering optimization. It has also been found to be robust in solving problems featuring non-linearity, non-differentiability and high dimensionality [17].

The proposed controller is tested on a ring connected three equal thermal power system areas under different parametric uncertainties in comparison with the Modified Chaotic Ant Swarm Optimization (MCASO) and Bacterial Foraging Optimization (BFO) fuzzy type PID controllers [18] through simulation results and some system performance indices. Results evaluation show that the proposed TSFPDC based PID controller has a simple natural procedure to handle nonlinear control of power system and achieve robust performance against wider range of uncertainties and superior to other controllers.

II. POWER SYSTEM DESCRIPTION

The LFC problem has been dealt with extensively for more than four decades. A comprehensive literatures review about the earlier studied in the field of LFC problem has been presented by Shayeghi et. al [1]. The power systems are usually large-scale systems with complex nonlinear dynamics. However, the major part of the work reported so far has been performed by considering the linearized models of two/multi area power systems. In advanced control strategies (such as the one considered in this paper) the error caused by simplification and linearization are considered as parametric uncertainties. A ring connected three equal thermal power system areas is taken as test system in this study which widely used in the literature [18, 19]. In each area, all generators are assumed to be coherent group. Figure 1 shows the block diagram of the system in detail. The nomenclature used and the nominal parameter values are given in [18].

In summary, The LFC goals for a power system are:

- Ensuring zero steady state error for the frequency deviations.
- Minimizing unscheduled tie line power flows between neighboring control areas.
- Getting good tracking for the load demands and disturbances.
- Maintaining acceptable overshoot and settling time on the frequency and tie-line power deviations

Based on the above objectives, a control signal made up of tie line power flow deviation added to frequency deviation weighted by a bias factor called *ACE* is used as the control signal in the LFC problem. *ACE* serves to indicate when total generation must be raised or lowered in a control area. By taking ACE_i as the system output, the PID controller transfer function in each control area over a given time interval s in Laplace domain is defined by, $(-G_i(s)ACE_i(s))$, where $G(s)$ is:

$$G_i(s) = K_{Pi} + \frac{K_{Ii}}{s} + K_{Di}s \tag{1}$$

where, K_p is the proportional gain, K_i is the integral gain and K_D is the derivative gain. It should be note that due to the innumerable on-off switching operations in the customer side, the measurements of systems frequency and tie-lines power flow are usually deteriorated by noise. In this case, the noise is greatly amplified in magnitude by differential term of the PID controller. For this reason, a low-pass filter is added to the differential feedback loop serially to solve the noise problem and practical implementation as follows:

$$G_i(s) = K_{Pi} + \frac{K_{Ii}}{s} + \frac{K_{Di}s}{1 + \tau_{Di}s} \tag{2}$$

where, $|\tau_{Di}| \ll 1$ and usually is considered $K_{Di}/100$. LFC goals, i.e. frequency regulation and tracking the load demands, maintaining the tie-line power interchanges to specified values in presence of modeling uncertainties, system nonlinearities and area load disturbances determines the LFC synthesis as a multi-objective optimization problem. For this reason, flexible controller must be developed.

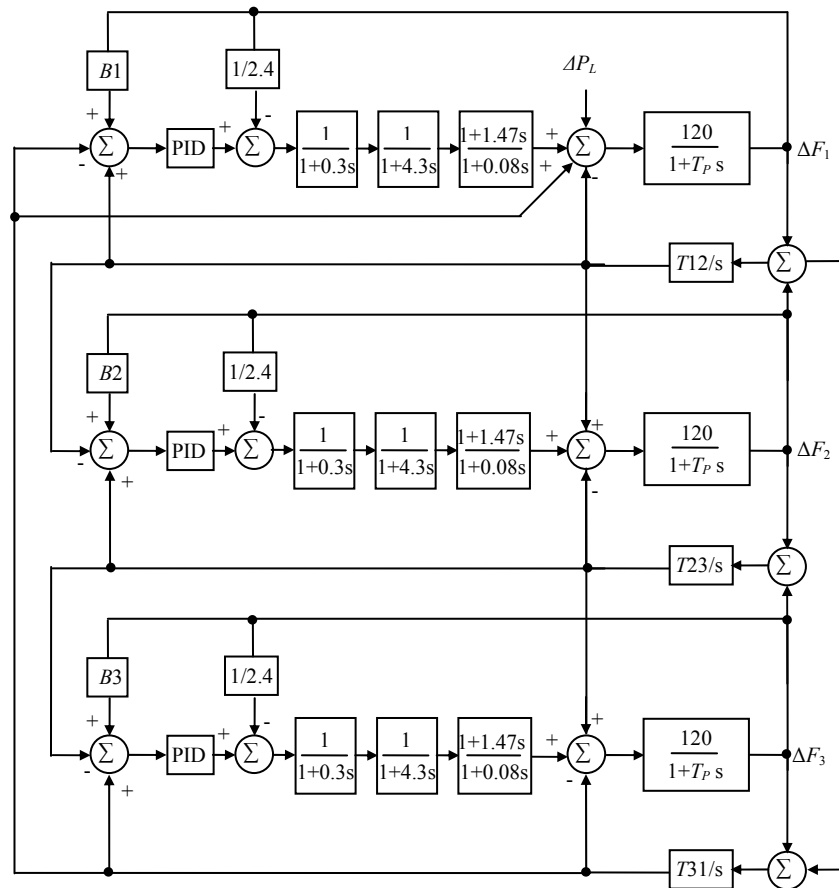

Figure 1. Block diagram of a three-area power system

III. TSFPDC CONTROL DESIGN SCHEME

A. The T-S Fuzzy Model

In this stage, the design procedure begins with representing a given nonlinear plant by the so-called Takagi-Sugeno (T-S) fuzzy model. The fuzzy model proposed by Takagi and Sugeno is described by the fuzzy IF-THEN rules which represent local linear input-output relations of a nonlinear system [20]. The main feature of a T-S fuzzy model is to express the local dynamics of each fuzzy implication (rule) by a linear system model. The overall fuzzy model of the system is achieved by the fuzzy “blending” of the linear system models. The *i*th rules of the T-S fuzzy models are of the following forms [13]:

Model Rule *i*:

If $Z_i(t)$ is M_{i1} ... and $Z_p(t)$ is M_{ip}

$$\text{Then } \begin{cases} \dot{x}(t) = A_i x(t) + B_i u(t) \\ y(t) = C_i x(t) \end{cases} \quad i = 1, 2, \dots, r \quad (3)$$

where, M_{ij} is the fuzzy set and r is the number of model rules; $x(t) \in R^n$ is the state vector, $u(t) \in R^m$ is the input vector, $y(t) \in R^q$ is the output vector, $A_i \in R^{n \times n}$, $B_i \in R^{n \times m}$, and $C_i \in R^{q \times n}$; $z_1(t), \dots, z_p(t)$ are known premise variables that may be functions of the state variables and external disturbances. Each linear consequent equation represented by $A_i x(t) + B_i u(t)$ is called a “subsystem”.

Given a pair of $(x(t), u(t))$, the final outputs of the fuzzy systems are inferred as follows:

$$\begin{aligned} \dot{x}(t) &= \frac{\sum_{i=1}^r \omega_i(z(t)) \{A_i x(t) + B_i u(t)\}}{\sum_{i=1}^r \omega_i(z(t))} = \\ &= \sum_{i=1}^r h_i(z(t)) \{A_i x(t) + B_i u(t)\} \quad (4) \\ y(t) &= \frac{\sum_{i=1}^r \omega_i(z(t)) C_i x(t)}{\sum_{i=1}^r \omega_i(z(t))} = \sum_{i=1}^r h_i(z(t)) C_i x(t) \end{aligned}$$

B. Parallel Distribution Compensation

The Parallel Distributed Compensation (PDC) offers a procedure to design a fuzzy controller from a given T-S fuzzy model. To realize the PDC, a controlled object (nonlinear system) is first represented by a T-S fuzzy model. In the PDC design, each control rule is designed from the corresponding rule of a T-S fuzzy model. The constructing following fuzzy controller via the PDC is given by [13]:

Control Rule *i*:

If $Z_i(t)$ is M_{i1} ... and $Z_p(t)$ is M_{ip}

$$\text{Then } u(t) = -F_i x(t) \quad i = 1, 2, \dots, r \quad (5)$$

The fuzzy control rules have a linear controller (PID control laws in this case) in the consequent parts. The overall fuzzy controller is represented by:

$$u(t) = -\frac{\sum_{i=1}^r \omega_i(z(t))F_i x(t)}{\sum_{i=1}^r \omega_i(z(t))} = -\sum_{i=1}^r h_i(z(t))F_i x(t) \quad (6)$$

The fuzzy controller design is to determine the gains of PID controller in the consequent parts. With PDC, we have a simple and natural procedure to handle the nonlinear control systems. Other nonlinear control techniques require special and rather involved knowledge.

C. TSFPDC Design

Because of the complexity and multi-variable conditions of the power system, conventional control methods may not give satisfactory solutions. On the other hand, their robustness and reliability make fuzzy controllers useful for solving a wide range of control problems in power systems. The origin of the power systems uncertainties are the continuous variations in the load patterns and transmission network. Since the system is to be linearized around the equilibrium point, it follows that a different system triple (A, B, C) is obtained for each operating point. It is assumed that the set of variables (T_p, T_{12}, B) of certain subsystem varies independently over the following ranges: $T_p \in [T_{p-}, T_{p+}]$, $T_{12} \in [T_{12-}, T_{12+}]$ and $B \in [B_-, B_+]$ [18]. These ranges are selected to encompass all practical operating points and very weak to very strong transmission networks. Possible combinations of minimum and maximum values of these variables result in eight operating points corresponding to the vertices of a cuboids in the (T_p, T_{12}, B) space. Consequently, a set of matrices obtained from an operating point can be represented by $(A, B, C) \in \Omega$, where:

$$\Omega = \{(A, B, C) : (A, B, C) = \sum_{i=1}^8 \alpha_i (A_i, B_i, C_i), \alpha_i \geq 0, \sum_{i=1}^8 \alpha_i = 1\} \quad (7)$$

The set Ω describes a polytope with eight vertices (A_i, B_i, C_i) , $i = 1, 2, \dots, 8$ calculated at $[T_{p-}, T_{12-}, B_-]$, $[T_{p-}, T_{12-}, B_+]$, \dots , $[T_{p+}, T_{12+}, B_+]$, respectively.

Changes in load and system topology or most of the system parameters lead to uncertainties in the state-matrix A . Uncertainties in the input matrix B can only caused by the parametric variations in the excitation system and are not taken into account in this study. Rotor speed deviation is selected as the measured output and thus, no uncertainties are appeared in the matrix C . Each vertex system in the polytope (Equation (7)) corresponds to a model rule in a T-S fuzzy system which is stated as:

Model Rule 1:

If $(T_p$ is T_{p-}) and $(T_{12}$ is T_{12-}) and $(B$ is $B_-)$

$$\text{Then } \begin{bmatrix} \dot{x} \\ y \end{bmatrix} = \begin{bmatrix} A_1 & B \\ C & 0 \end{bmatrix} \begin{bmatrix} x \\ u \end{bmatrix}$$

Model Rule 2:

If $(T_p$ is $T_{p-})$ and $(T_{12}$ is $T_{12-})$ and $(B$ is $B_+)$

$$\text{Then } \begin{bmatrix} \dot{x} \\ y \end{bmatrix} = \begin{bmatrix} A_2 & B \\ C & 0 \end{bmatrix} \begin{bmatrix} x \\ u \end{bmatrix}$$

Model Rule 8:

If $(T_p$ is $T_{p+})$ and $(T_{12}$ is $T_{12+})$ and $(B$ is $B_+)$

$$\text{Then } \begin{bmatrix} \dot{x} \\ y \end{bmatrix} = \begin{bmatrix} A_8 & B \\ C & 0 \end{bmatrix} \begin{bmatrix} x \\ u \end{bmatrix}$$

The resulting fuzzy system is inferred as the weighted average of the local models and is given as:

$$\begin{bmatrix} \dot{x} \\ y \end{bmatrix} = \begin{bmatrix} \sum_{i=1}^8 (\omega_i A_i) & B \\ C & 0 \end{bmatrix} \begin{bmatrix} x \\ u \end{bmatrix} \quad (8)$$

any value $T_p \in [T_{p-}, T_{p+}]$ can be expressed as $T_p = L_1(T_{p-}, T_{p+}, T_p) \times T_{p-} + L_2(T_{p-}, T_{p+}, T_p) \times T_{p+}$, where, $L_1(T_{p-}, T_{p+}, T_p)$ and $L_2(T_{p-}, T_{p+}, T_p)$ are the membership functions for the variable T_p such that $L_1(T_{p-}, T_{p+}, T_p) + L_2(T_{p-}, T_{p+}, T_p) = 1$, and consequently these membership functions can be calculated as:

$$L_1(T_{p-}, T_{p+}, T_p) = \frac{T_{p+} - T_p}{T_{p+} - T_{p-}} \quad (9)$$

$$L_2(T_{p-}, T_{p+}, T_p) = \frac{T_p - T_{p-}}{T_{p+} - T_{p-}}$$

The membership functions $L_1(T_{p-}, T_{p+}, T_p)$ and $L_2(T_{p-}, T_{p+}, T_p)$ are labeled "L1" and "L2", respectively. Figure 2-a shows the membership functions for the variable T_p . Similarly, the membership functions for T_{12} and B are defined and labeled M_1, M_2 and N_1, N_2 , respectively. Figures 2-b, 2-c show membership functions for variable T_{12} and B , respectively. The weights are calculated as $h_1 = L_1 M_1 N_1, h_2 = L_1 M_1 N_2, h_3 = L_1 M_2 N_1, \dots$, and $h_8 = L_2 M_2 N_2$.

Typically, in a LFC design and operation the ACE is used as a control signal. In such case, attention is oriented towards the PID control design methods [13]. This is because it performs well for a wide class of process, gives robust performance and easy to implement. Thus, the design of the PID control based LFC for power system is described by continuous T-S fuzzy models. Figure 3 shows the diagram of the proposed TSFPDC controller. A fuzzy based PID controller shares the same fuzzy sets with the fuzzy model as follows:

$$u(t) = \sum_{i=1}^8 \omega_i F_i y(t) = \sum_{i=1}^8 \omega_i \omega_j \{F_i C_j x(t)\} \quad (10)$$

where, F_i are the local output feedback gains to be determined. By substituting Equation (11) in T-S model (9), we have:

$$\dot{x}(t) = \sum_{i=1}^8 \sum_{j=1}^8 \sum_{l=1}^8 \omega_i \omega_j \omega_l \{A_i + B_l F_j C_l\} x(t) \quad (11)$$

For the case of power systems, $B_l = B, C_l = C, i, l = 1, 2, \dots, r$. Then Equation (12) can be rewritten as:

$$\dot{x}(t) = \sum_{i=1}^8 \omega_i \{A_i + B F_i C\} x(t) \quad (12)$$

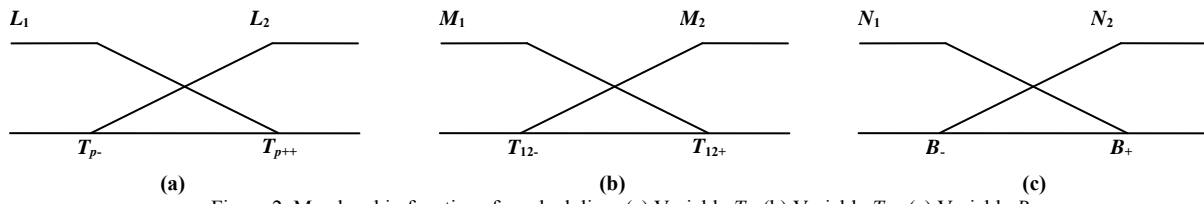

Figure 2. Membership functions for scheduling: (a) Variable T_p ; (b) Variable T_{12} ; (c) Variable B_i

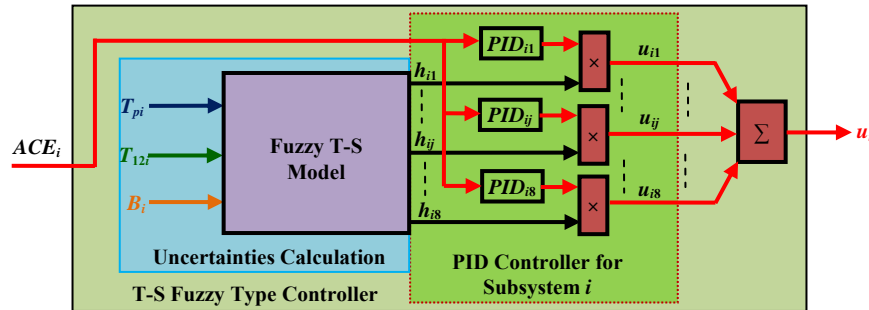

Figure 3. Schematic diagram of the proposed TSFPDC

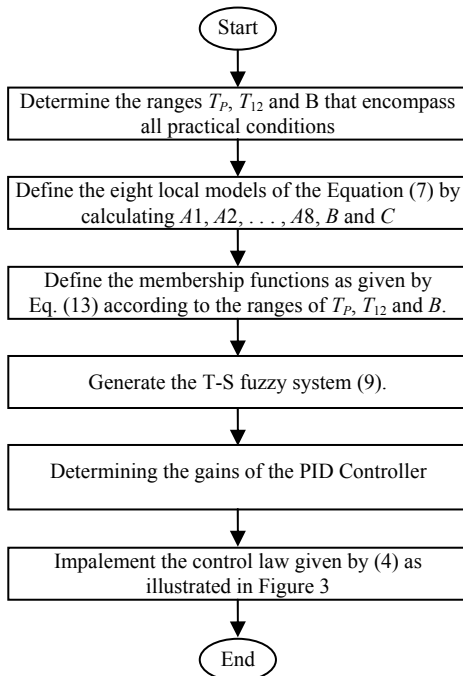

Figure 4. Flowchart of the design steps in the proposed method

The Flowchart of the design steps using the proposed method is shown in Figure 4. In order for a proposed fuzzy based control system to perform well, the gains of the PID controller in each subsystem must be carefully designed. Because, it is a computationally expensive combinational optimization problem and also extraction of an appropriate set of static gains for all subsystem may be tedious, time consuming and process specific. Thus, the optimal tuning of a PID gains is required to get the desired level of robust performance. In recent years, global optimization techniques like genetic algorithms [21], simulated annealing [19], and honey bee mating optimization [22] have been applied for optimal tuning of the PID based LFC schemes. These evolutionary algorithms are heuristic population-based search procedures that incorporate random variation and

selection operators. Although, these methods seem to be good methods for the solution of the PID parameter optimization problem, however, when the system has a highly epistatic objective function (i.e. where parameters being optimized are highly correlated), and the number of parameters to be optimized is large, then they have degraded efficiency to obtain global optimum solution. Recently, Particle Swarm Optimization (PSO) has been successfully applied for the off-line optimal tuning gains of the fuzzy based PID type controllers [18, 23]. For this reason, PSO technique is used for optimal tune of the PID controller gains of each control area in an operation condition which have the features of easy implementation, short execution time and robust mechanisms of escaping from the local optimum. Also, it is a promising tool for the engineering applications (see Appendix for more details).

To acquire an optimal combination, this paper employs the PSO [24] to improve the optimization synthesis and find the global optimum value of the fitness function. It should be noted that the choice of the properly fitness function is very important in the synthesis procedure. Because, different fitness functions promotes different PSO behaviors. For our optimization problem, an ISTSE performance index is taken as the objective function as follows:

$$ISTSE = \int_0^{10} t^2 (\Delta f_1^2 + \Delta p_{tie12}^2) dt \quad (13)$$

For the objective function calculation, the time-domain simulation of the power system model is carried out for the simulation period. It is aimed to minimize this objective function in order to improve the system response in terms of the settling time and overshoots. The design problem can be formulated as the following constrained optimization problem, where the constraints are the controller parameters bounds:

$$\text{minimize } ISTSE \text{ subject to: } K_i^{\min} \leq K_i \leq K_i^{\max} \quad (14)$$

Typical range of the optimized parameter is [0, 2]. The proposed approach employs PSO algorithm to solve this optimization problem and search for an optimal set of output feedback controller parameters.

IV. TSFPDC BASED LFC CONTROLLER DESIGN

In this study, three area interconnected power systems shown in Figure 1 is considered as a test system. Detail of the system data are given in [18]. It is assumed that the set of variables (T_p, T_{12}, B) of certain subsystem varies independently over the following ranges: $T_p \in [10 \ 30]$, $T_{12} \in [0.145 \ 0.545]$ and $B \in [0.125 \ 0.425]$. The eight local models of the Equation (11) are defined according to the eight loading condition which are given in Table 1.

Table 1. The eight loading condition

	Case 1	Case 2	Case 3	Case 4	Case 5	Case 6	Case 7	Case 8
T_p	10	10	10	10	30	30	30	30
T_{12}	0.145	0.145	0.545	0.545	0.145	0.145	0.545	0.545
B	0.125	0.425	0.125	0.425	0.125	0.425	0.125	0.425

In order to acquire better performance, number of particle, particle size, number of iteration, c_1 and c_2 are chosen as: 30, 3, 100, 2 and 2, respectively. Also, the inertia weight, w , is linearly decreasing from 0.9 to 0.4. Because of the stochastic nature of the proposed PSO, four trials are performed with 100 iterations and the best solution amongst them is considered as the final solution. The near optimal solution is achieved after approximately 50 iterations. The optimal PID controller gains in the proposed method for the different operation conditions as given in Table 1 using the multi objective function of Equation (18) are listed in Table 2.

Table 2. Optimal PID gains for each area control

	Case 1	Case 2	Case 3	Case 4	Case 5	Case 6	Case 7	Case 8
K_p	2	2	0.5	2	2	2	2	2
K_i	1.2	0.58	1.04	2	1	0.54	1.14	0.77
K_d	1.38	0.62	2	0.92	2	1.09	2	1.143

V. SIMULATION RESULTS

To assess the effectiveness and robustness of the proposed method over a wide range of uncertain plant parameter changes, four different scenarios are considered. The effectiveness of the proposed TSFPDC based LFC controller is tested on a three area interconnected power system under different operation conditions in comparison with the Modified Chaotic Ant Swarm Optimization (MCASO) and Bacterial Foraging Optimization (BFO) based designed fuzzy PID controllers [16] through simulation results and some system performance indices.

A. Scenario 1

It is assumed that the $T_p=10$, $T_{12}=0.145$, $B=0.125$ and a step load disturbance 0.01 puMW is applied to one area. Power system responses in area 1, ΔF_1 , ΔP_{tie1} and ΔP_{g1} are shown in Figure 5. Using the proposed method, the frequency deviation is quickly driven back to zero and has

very small settling time without overshoot. Also the tie-line power flow deviation properly converges to the zero.

B. Scenario 2

In this scenario the T_p, T_{12} and B is considered 10, 0.145 and 0.275, respectively and a step load equal to 0.01 puMW is accrued in area 1. Power system responses are shown in Fig. 6. It can be seen that the proposed method has good damping characteristics and stabilizes the system quickly.

C. Scenario 3

In this scenario the T_p, T_{12} and B is considered 24, 0.28 and 0.132, respectively and a step load equal 0.01 puMW is applied to one area. Power system responses in area 1, ΔF_1 , ΔP_{tie1} and ΔP_{g1} . are shown in Figure 7. Using the proposed method, the frequency deviation is quickly driven back to zero and has very small settling time without overshoot. Also, the tie-line power flow deviation properly converges to zero.

D. Scenario 4

Consider case 1 again, a bounded random step load change as a large demand as shown in Fig. 8-a appears in one control area, where: $-0.5 \leq \Delta P_{di} \leq +0.5$ puMW. The purpose of this scenario is to test the robustness of the proposed controller against uncertainties and random large load disturbances. The frequency deviation of area 1 in this case are shown in Fig. 8-b. The simulation results demonstrate that the proposed control strategy track the load fluctuations and meet robustness for a wide range of load disturbances under plant parameter changes.

To demonstrate the performance robustness of the proposed method, some performance indices based on the system performance characteristics are defined as:

$$IAE = 100 \int_0^{10} (|\Delta f_1| + |\Delta p_{tie_{12}}|) dt \tag{15}$$

$$ISE = 10000 \int_0^{10} (\Delta f_1^2 + \Delta p_{tie_{12}}^2) dt \tag{16}$$

$$ITAE = 100 \int_0^{10} t (|\Delta f_1| + |\Delta p_{tie_{12}}|) dt \tag{17}$$

$$ITSE = 10000 \int_0^{10} t (\Delta f_1^2 + \Delta p_{tie_{12}}^2) dt \tag{18}$$

$$ISTSE = 10000 \int_0^{10} t^2 (\Delta f_1^2 + \Delta p_{tie_{12}}^2) dt \tag{19}$$

$$FD = 0.01((100 \times OS)^2 + (60 \times US_i)^2 + (1.4 \times Ts_i)^2) \tag{20}$$

where, Overshoot (OS), Undershoot (US) and settling time (for 5% band) of the frequency deviation of area 1 is considered for the evaluation of the FD . It is worth mentioning that the lower the values of these indices are, the better the system response in terms of the time-domain characteristics. Numerical results of the performance robustness for all above scenarios are shown in Tables 3. It can be seen that the values of these system

performance characteristics with the proposed control strategy are much smaller in comparison with the BFO and MCASO based designed controllers. This

demonstrates that the overshoot, undershoot, settling time and frequency deviations each control area are greatly reduced by applying the proposed TSFPDC controller.

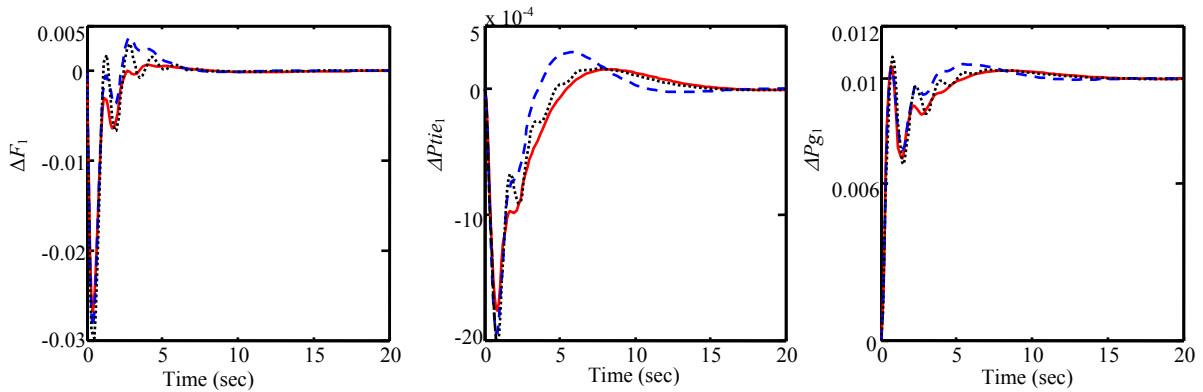

Figure 5. Power system response in scenario 1, Solid (TSFPDC), Dashed (BFO), Dotted (MCASO)

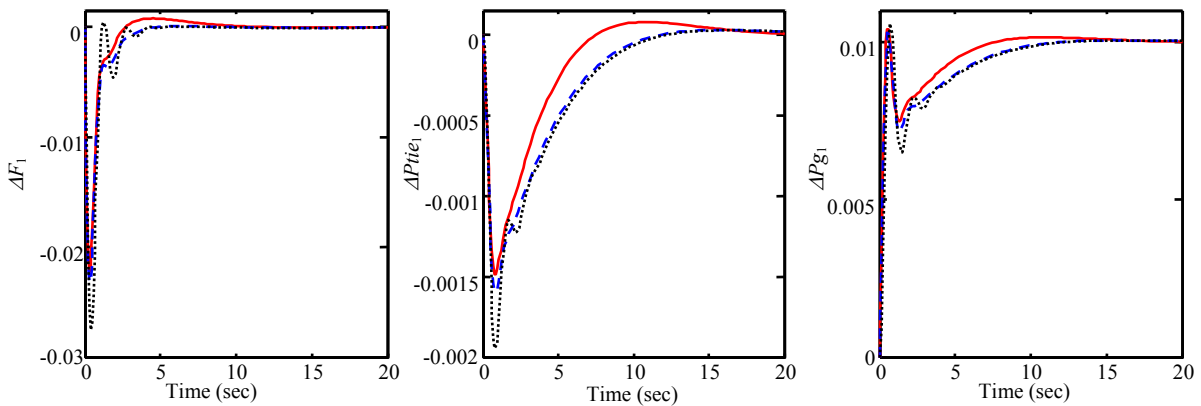

Figure 6. Power system response in scenario 2, Solid (TSFPDC), Dashed (BFO), Dotted (MCASO)

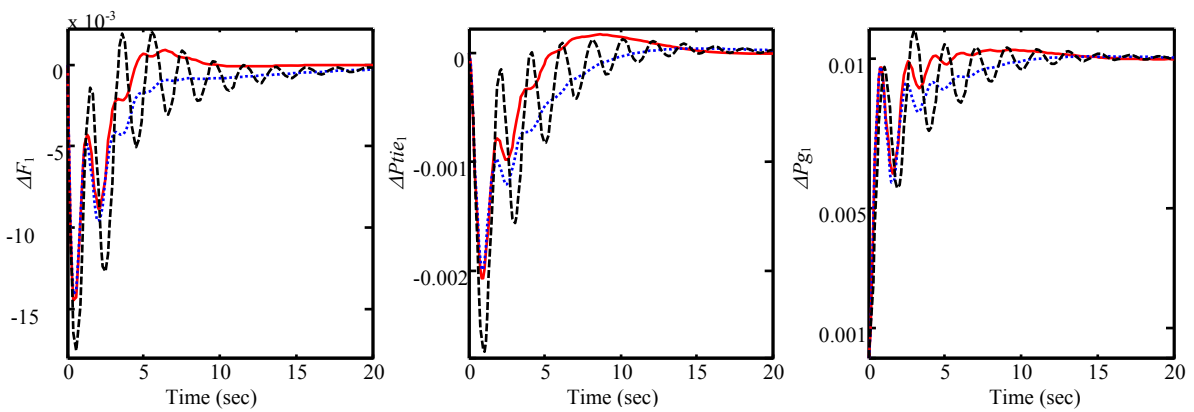

Figure 7. Power system response scenario 3, Solid (TSFPDC), Dashed (BFO), Dotted (MCASO)

Table 3. Different performance indices value

	Scenario1			Scenario 2			Scenario 3		
	TSF	MCASO	BFO	TSF	MCASO	BFO	TSF	MCASO	BFO
<i>IAE</i>	2.9192	3.1635	3.3188	2.4603	2.81	2.6381	3.2505	4.488	4.1731
<i>ISE</i>	3.8058	4.751	4.3671	2.4287	3.8497	2.7772	2.2007	3.6181	2.555
<i>ITAE</i>	3.9607	4.4432	5.6813	4.1055	3.8196	3.7664	6.7307	12.2328	11.2718
<i>ITSE</i>	2.1286	2.7318	2.6969	1.2256	2.0054	1.4605	2.6927	5.9853	4.0502
<i>ISTSE</i>	2.0018	2.7797	3.7346	1.3813	1.7863	1.404	5.3571	18.0174	11.0402
<i>FD</i>	3.1588	12.525	17.0257	1.8797	2.9945	2.1305	1.6702	2.8199	2.6704
<i>T_s</i>	2.458	4.805	5.723	2.3203	3.6989	3.1677	6.8282	9.2259	10
<i>US%</i>	-2.6745	-2.998	-2.8521	-2.2161	-2.7509	-2.3176	-1.4417	-1.757	-1.4048
<i>OS%</i>	0.6821	2.9727	3.6681	0.7821	0.4614	0.0992	0.9008	2.0058	0

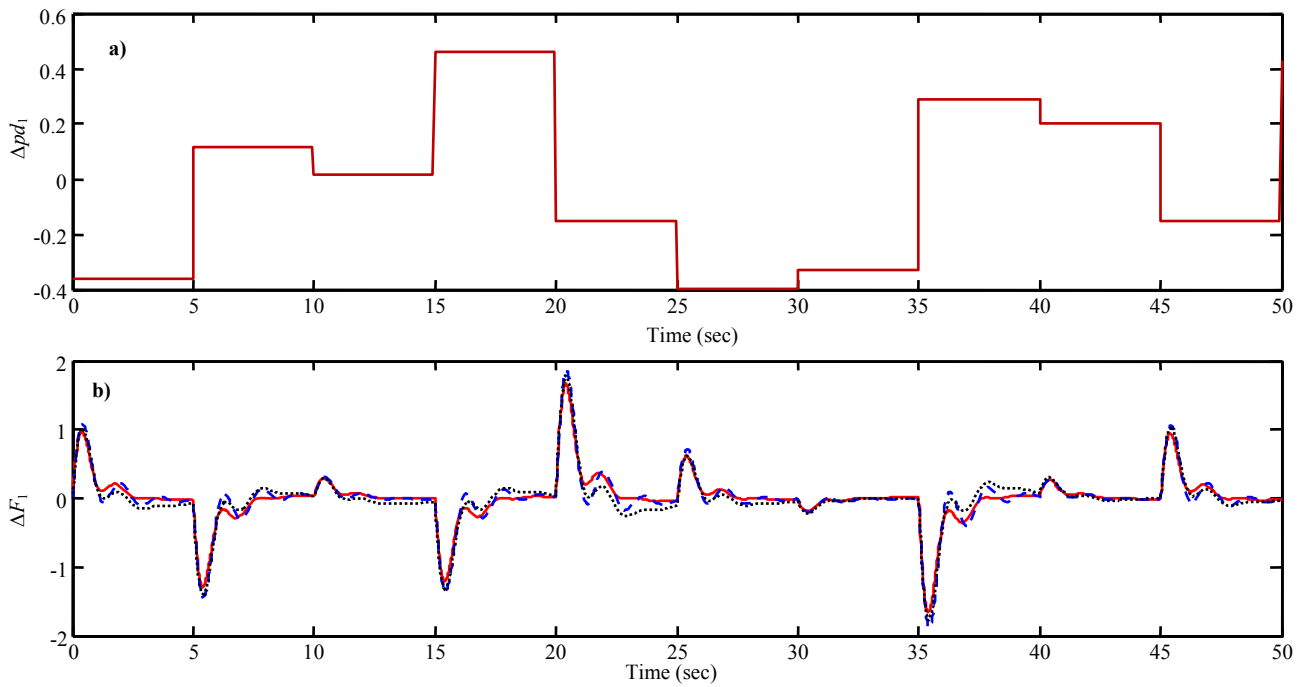

Figure 8. Frequency Deviation of area 1 in scenario 4, Solid (TSFPDC), Dashed (BFO), Dotted (MCASO)

Remark 5.1: Examination of Table 3 reveals that the proposed control strategy achieves good robust performance against various operation conditions and disturbance and it is superior to other controllers.

Remark 5.2: We have considered different cases for stabilizing the systems frequency oscillations. The simulation results show that in comparison with the BFO and MCASO based designed fuzzy controller; the system performance is significantly improved by the proposed TSFPDC controller in this paper under different operating conditions and disturbances in present of system parametric uncertainties.

VI. CONCLUSIONS

In this paper, a robust Takagi-Sugeno fuzzy parallel distribution compensation technique is proposed for the solution of LFC problem. This control strategy was chosen because of increasing the complexity and changing structure of power systems. This newly developed control strategy combines advantage of both fuzzy logic theory and linear system theory. Considering (T_p, T_{12}, B) as uncertain parameters has enough flexibility for setting the desired level of robust performance and leads to a set of simple controllers to achieve the desired level of robust performance. In order to reduce design effort and find better fuzzy system control, LFC design problem has been formulated as a multi objective optimization control problem via TSFPDC control approach and solved by the PSO technique to obtain the optimal gains of the PID controllers. The effectiveness of the proposed strategy was tested on a three-area interconnected power system and compared with the BFO and MCASO method based designed fuzzy PID controller under various conditions through IAE , ISE , $ITAE$, $ITSE$, $ISTSE$ and FD performance indices.

The simulation results show that that the proposed method achieves good robust performance such as damping the frequency oscillations and load tracking for wide range of load change in the presence of system nonlinearity and disturbances and is superior to other controllers. Thus, the promising control strategy is ideally practical for the real world complex power systems.

APPENDIX PSO TECHNIQUE

The particle swarm optimization technique is a populated search method for the optimization of the continuous non-linear functions resembling to the movement of organisms in a bird flock or fish school. As in the evolutionary computation paradigms, the concept of the fitness is employed and candidate solutions to the problem are termed particles or sometimes individuals, each of which adjusts its flying based on the flying experiences of both itself and its companion. It keeps track of its coordinates in hyperspace which are associated with its previous best fitness solution and also of its counterpart corresponding to the overall best value acquired thus far by any other particle in the population [24].

The fundamental principles of the swarm intelligence are adaptability, diverse response, proximity, quality, and stability. It is adaptive corresponding to the change of the best group value. PSO starts with a population of random solutions "particles" in a D-dimension space. The i th particle is represented by $X_i=(x_{i1}, x_{i2}, \dots, x_{iD})$. Each particle keeps track of its coordinates in hyperspace, which are associated with the fittest solution it has achieved so far. The value of the fitness for particle i (p_{best}) is also stored as $P_i=(p_{i1}, p_{i2}, \dots, p_{iD})$.

The global version of the PSO keeps track of the overall best value (g_{best}), and its location, obtained thus

far by any particle in the population. PSO consists of, at each step, changing the velocity of each particle toward its p_{best} and g_{best} according to Equation (21). The velocity of the particle i is represented as $V_i=(v_{i1}, v_{i2}, \dots, v_{id})$. Acceleration is weighted by a random term, with separate random numbers being generated for acceleration toward the p_{best} and g_{best} . The position of the i th particle is then updated according to Equation (22) [25].

$$v_{id} = \omega \times v_{id} + c_1 \times \text{rand}(\) \times (P_{id} - x_{id}) + c_2 \times \text{rand}(\) \times (P_{gd} - x_{id}) \quad (21)$$

$$x_{id} = x_{id} + v_{id} \quad (22)$$

where, P_{id} and P_{gd} are p_{best} and g_{best} , respectively. Several modifications have been proposed in the literature to improve the PSO algorithm speed and convergence toward the global minimum. One modification is to introduce a local-oriented paradigm (l_{best}) with different neighborhoods and another improved via using a time decreasing inertia weight, which leads to a reduction in the number of iterations. Figure 9 shows the flowchart of the proposed PSO algorithm [25].

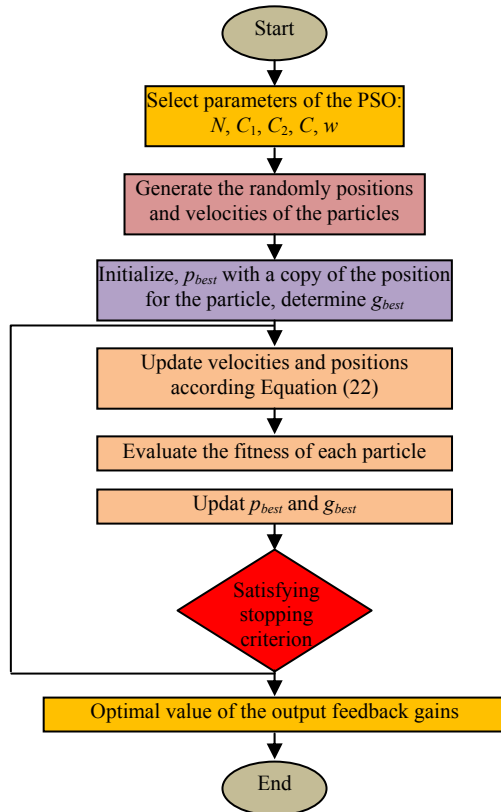

Figure 9. Flowchart of the PSO technique [25]

REFERENCES

[1] H. Shayeghi, H.A. Shayanfar and A. Jalili, "Load Frequency Control Strategies: A State-of-the-Art Survey for the Researcher", Energy Conversion and Management, Vol. 49, pp. 344-353, 2008.
 [2] H. Shayeghi, H.A. Shayanfar, A. Jalili and A. Ghasemi, "Honey Bee Mating Optimization Scheme for Load Frequency Control", 6th International Conference on Technical and Physical Problems of Power

Engineering (ICTPE-2010), pp. 329-334, Tabriz, Iran, 14-16 September 2010.

[3] G. Zarighavar, H. Shayeghi, A. Sakhavati and S.H. Hosseini, "PID Type LFC Design Consideration Uncertainties and Nonlinearities in Power System using PSO", Proceedings of the 24th International Power Systems Conference, pp. 1-6, Tehran, Iran, 2010.
 [4] H. Jiang, H. Cai, F. Dorsey and Z. Qu, "Toward a Globally Robust Decentralized Control for Large-Scale Power Systems", IEEE Trans. on Control System Technology, Vol. 5, No. 3, pp. 309-319, 1997.
 [4] Z.M. Al-Hamouz and H.N. Al-Duwaish, "A New Load Frequency Variable Structure Controller using Genetic Algorithms", Electric Power Systems Research, Vol. 55, No. 1, pp. 1-6, 2000.
 [5] H. Shayeghi and H.A. Shayanfar, "Application of ANN Technique based on μ -Synthesis to Load Frequency Control of Interconnected Power System", Electrical Power and Energy Systems, Vol. 28, pp. 503-511, 2006.
 [6] C.M. Liaw, "Design of a Reduced-Order Adaptive LFC for an Interconnected Hydrothermal Power System", International Journal of Control, Vol. 60, No. 6, pp. 1051-1063, 1994.
 [7] M.H. Kazemi, M. Karrari and M.B. Menhaj, "Decentralized Robust Adaptive-Output Feedback Controller for Power System Load Frequency Control", Electrical Engineering, Vol. 84, No. 2, pp. 75-83, 2002.
 [8] H. Shayeghi, "A Robust Decentralized Power System Load Frequency Control", Journal of Electrical Engineering, Vol. 59, No. 6, pp. 281-293, 2008.
 [9] M. Karrari, H. Shayeghi, M. Abedi and M.B. Menhaj, "Design of H_∞ Controller Load Frequency Control in Electrical Power Systems", Amirkabir Journal of Science and Technology, Vol. 11, No. 41, pp. 79-88, 1999.
 [10] H. Bevrani, Y. Mitani and K. Tsuji, "Sequential Design of Decentralized Load Frequency Controllers using μ Synthesis and Analysis", Energy Conversion and Management, Vol. 45, No. 6, pp. 865-881, 2004.
 [11] S.P. Ghoshal, "Optimizations of PID Gains by Particle Swarm Optimizations in Fuzzy based Automatic Generation Control", Electric Power Systems Research, Vol. 70, No. 3, pp. 203-212, 2004.
 [12] A. Jalili, H. Shayeghi and H.A. Shayanfar, "T-S Fuzzy Parallel Distribution Compensation Controller for Power System Stabilizer", 5th International Conference on Technical and Physical Problems of Engineering (ICTPE-2009), pp. 180-184, Bilbao, Spain, 3-5 September 2009.
 [13] K. Tanaka and H. Wang, "Fuzzy Control Systems Design and Analysis: A Linear Matrix Inequality Approach", New York: Wiley, 2001.
 [14] T. Guerra, L. Vermeiren, "LMI-based Relaxed Nonquadratic Stabilization Conditions for Nonlinear Systems in the Takagi-Sugeno's Form", Automatica, Vol. 40, pp. 823-829, 2004.
 [15] A. Khodabakhshian and M. Edrisi, "A New Robust PID Load Frequency Controller", Control Engineering Practice, Vol. 16, pp. 1069-1080, 2008.

- [16] W. Tan, "Tuning of PID Load Frequency Controller for Power Systems", *Energy Conversion and Management*, Vol. 50, pp. 1465-1472, 2009.
- [17] H. Shayeghi, H.A. Shayanfar and A. Jalili, "Multi stage fuzzy load frequency control using PSO", *Energy Conversion and Management*, Vol. 49, pp. 2570-2580, 2008.
- [18] R. Roy, P. Bhatt and S.P. Ghoshal, "Evolutionary Computation based Three-Area Automatic Generation Control", *Expert Systems with Applications*, Vol. 57, 2010.
- [19] S.P. Ghoshal, "Application of GA/GA-SA based Fuzzy Automatic Generation Control of a Multi-Area Thermal Generating System", *Electric Power Systems Research*, Vol. 70, pp. 115-127, 2004.
- [20] M. Soliman, A. Elshafei, F. Bendary, "LMI Static Output Feedback Design Fuzzy Power System", *Expert Systems with Applications*, Vol. 56, pp. 6817-6825, 2009.
- [21] S.K. Aditya and D. Das, "Design of Load Frequency Controllers using Genetic Algorithm for Two-Area Interconnected Hydro Power System", *Electrical Power Component Systems*, Vol. 31, No. 1, pp. 81-94, 2003.
- [22] H. Shayeghi, H.A. Shayanfar, A. Jalili and A. Ghasemi, "LFC Design using HBMO Technique in Interconnected Power System", *International Journal of Technical and Physical Problems of Engineering (IJTPE)*, Issue 5, Vol. 2, No. 4, pp. 41-48, December 2010.
- [23] S.P. Ghoshal, "Optimizations of PID Gains by Particle Swarm Optimizations in Fuzzy based Automatic Generation Control", *Electric Power Systems Research*, Vol. 70, pp. 203-212, 2004.
- [24] H. Shayeghi, H.A. Shayanfar, A. Jalili, A. Safari and R. Aghmasheh, "A Robust PSSs Design using PSO in a Multi Machine Environment", *Energy Conversion and Management*, Vol. 51, pp. 696-702, 2010.
- [25] H. Shayeghi, H.A. Shayanfar, "PSO based Neuro-Fuzzy Controller for LFC Design Including Communication Time Delays", *International Journal of Technical and Physical Problems of Engineering (IJTPE)*, Issue 3, Vol. 2, No. 2, pp. 28-36, June 2010.

BIOGRAPHIES



Heidar Ali Shayanfar received the B.S. and M.S.E. degrees in Electrical Engineering in 1973 and 1979, respectively. He received his Ph.D. degree in Electrical Engineering from Michigan State University, U.S.A., in 1981. Currently, he is a Full Professor in Electrical Engineering Department

of Iran University of Science and Technology, Tehran, Iran. His research interests are in the Area of Application of Artificial Intelligence to Power System Control Design, Dynamic Load Modeling, Power System Observability Studies, Voltage Collapse, Congestion Management in a Restructured Power System, Reliability Improvement in Distribution Systems and Reactive Pricing in Deregulated Power Systems. He has published more than 140 papers in international journals and 214 papers in conference proceedings. He is a member of the Iranian Association of Electrical and Electronic Engineers and IEEE.



Hossein Shayeghi received the B.S. and M.S.E. degrees in Electrical and Control Engineering in 1996 and 1998, respectively. He received his Ph.D. degree in Electrical Engineering from Iran University of Science and Technology, Tehran, Iran in 2006. Currently, he is an Associated

Professor in Technical Engineering Department of University of Mohaghegh Ardabili, Ardabil, Iran. His research interests are in the Application of Robust Control, Artificial Intelligence and Heuristic Optimization Methods to Power System Control Design, Operation and Planning and Power System Restructuring. He has authored of five books in Electrical Engineering area (all in Persian language). He has published more than 172 papers in international journals and conference proceedings. He is a member of Iranian Association of Electrical and Electronic Engineers (IAEEE) and IEEE.

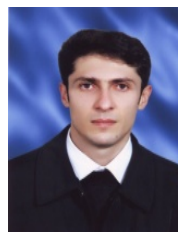

Aref Jalili received the B.S. and M.S.E. degrees in Electrical Engineering from Islamic Azad University, Ardabil and South Tehran Branches, Iran in 2003 and 2005, respectively. Currently, he is a Ph.D. student in Electrical Eng. Department of Islamic Azad University, Science

and Research Branch, Tehran, Iran. His areas of interest in research are the Application of Fuzzy Logic and Genetic Algorithm to Power System Control and Restructuring.