

RECONSTRUCTION OF STRUCTURAL ELEMENTS DAMAGED UNDER INFLUENCE OF PRESSURE AND WAVE ON STATIONARY SEA PLATFORMS

A.I. Khudiyeva M.Z. Yusifov

*Azerbaijan University of Architecture and Construction, Baku, Azerbaijan
aynur-khudiyeva@rambler.ru, maarif_yusifov@mail.ru*

Abstract- Shell constructions are widely used in modern technology. Combining low weight with high strength, shells are the most common structural elements. Thin-walled shell type elements are used in engineering structures, in transport and chemical engineering, in industrial and civil construction, in aviation, missile and ship constructions. Among all types of shells used by human of greatest interest are cylindrical shells in which simplicity, compactness and high technology are successfully combined.

Circular cylindrical shells are the elements in constructions of aircrafts and engines, underwater and surface vehicles, underground tunnels and tanks. When considering vibrational processes of cylindrical shells, the choice of a suitable model is principal. The first aspect is the choice of the type of vibration: nonlinear or linear ones. The second important point is the answer to the question if the shell may be considered as infinite, or it has a finite length, that immediately complicates the problem in connection with the need to satisfy boundary conditions at the ends (or at the end if the shell is considered as semi-infinite). The third aspect in the choice of the model is the establishment of possibility of using theories of thin shells which is allowed when the ratio of the thickness to the median radius is less than 0.05. Otherwise, we have to use mathematical apparatus of three-dimensional theory of elasticity.

In great majority of classic fundamental studies, physical and mathematical characteristics of the material were considered constant, i.e., homogeneous shells were considered. At the same time, the research of the stress-strain state of circular cylindrical shells inhomogeneous in thickness under dynamical actions are extremely important from practical point of view if we take into attention that such shells are used as protective structures of AES. When designing protective shells for AES it is necessary to take into account various emergency situations including action of air shock, as well as sudden increase of pressure, radiation and temperature. At the same time, in the rated models it is necessary to take into account change of elastic and inertial characteristics in the thickness of the construction, and resulting dynamical reactions may turn out to be defining.

However, in normative documents there are no recommendations on calculation of shells for the specified actions. Thus, under the conditions of increased safety requirements for AES development of the technique for calculating protective shells for the above noted special dynamical actions is a very serious problem. In the modern conditions of exploitation of special responsible structures which include protective shells of reactor compartment of nuclear powers, energetic and chemical reactors, constructions of reservoirs, chimney stack, technological furnaces along with force (static, dynamic) loadings are also affected by various physical, mechanical and chemical fields. So, action of radiation exposure, aggressive media, intense temperature and high pressure lead to change in physical and strength characteristics of the material of such constructions, i.e. they are induced heterogeneity factors. In this regard, it becomes necessary to determine dynamical characteristics and analysis of stress-strain state of shells inhomogeneous in thickness with altered physical and mechanical characteristics of the material. At the same time, there is still no established calculation methodology for analysis of inhomogeneous cylindrical shells for dynamical action. The issues related to calculation of multilayer shells under nonstationary loadings also were not enough studied.

In the present paper we study vibrations of a viscous fluid-filled orthographic shell stiffened with cross system of ribs.

Keywords: Vibration, Stiffened Shell, Orthotropic Cylindrical Shell, Viscous Fluid.

1. INTRODUCTION

The Azerbaijan is an oil country. More than 80 percent of the oil produced is extracted from the sea water area and is transported to the shore via pipelines. Extraction of oil from the sea is always accompanied by serious difficulties, because storm and hurricanes that occur at sea at different times of the year always cause complications on stationary platforms built for oil extraction.

The parts of stationary platforms that require regular attention and break down quickly, are the pipes where the oil collected from the wells is connected to the subsea pipeline (sometimes 8-10 oil wells are located on one stationary platform in Figure 1).



Figure 1. Stationary platform in the sunny equatorial of the Caspian Sea

During strong storms as well as under the influence of underwater current, the cracks appear at the junction of the subsea pipeline with the platform and at the junction of pipelines from the oil well due to internal pressure (there is a pressure of about 100 atmosphere) resulting in major accidents. One such incident occurred in December 4, 2015 in the Gunashli water area of the Caspian Sea (140 km from the shore, the depth of the sea was 130 m and the pressure in the gas pipeline was 110 atm) in one of the off shore stationary platforms (well No. 10). The accident resulted in numerous casualties and it took several months to extinguish the fire (Figure 2).

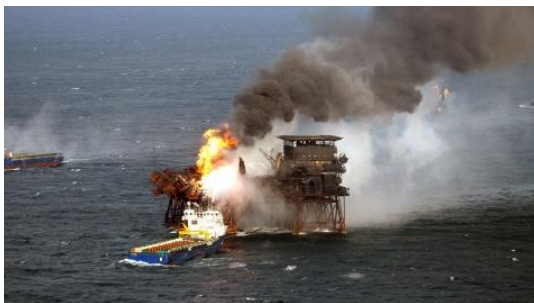

Figure 2. Stationary platform in case of fire

Engineers and scientists were invited to restore the damaged (torn along the axis) horizontal and inclined distribution pipelines (Figures 3 and 4) and the restoration was completed with scientific research.



Figure 3. Damaged horizontal distribution pipe



Figure 4. Damaged inclined distribution pipe

The present paper was devoted to the elimination of the accident. The structural elements damaged as a result of the accident were restored and strengthened (Figures 5 and 6).

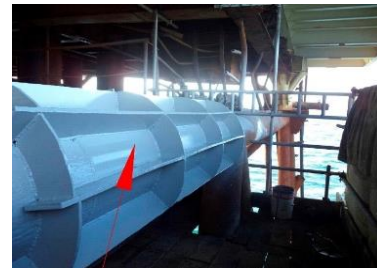

Figure 5. Restored horizontal distribution pipe



Figure 6. Restored inclined distribution pipe

Equations describing deformation waves by means of asymptotic methods of solution of a coupled problem of hydroelasticity that includes equations of dynamics of two co-axial geometrically and physically nonlinear elastic shells taking into account energy dissipation and equations of dynamics of viscous incompressible fluid between cylindrical shells, with appropriate boundary conditions were obtained in [1].

Two cases of properties of the shell material are considered: with structural damping and viscoelastic behavior. It is shown that in both cases one and the same equations generalizing the known Kortewag-de Vries-Burgers modified equation are obtained.

Existence of fluid between co-axial shells leads to appearance of deformation wave not only in external shell, but also in the internal one, which at initial moment of deformation were equal to zero. As a result, in the external and internal shells it is established a deformation wave of constant amplitude and propagation speed with a local splash on leading edge, that corresponds to the "solitary wave" type solution that is not described analytically. This construction can be interpreted as a three-layer package whose filler is fluid.

The features of vibrations of a cylindrical shell inhomogeneous in its reinforced thickness and being in dynamic contact with moving liquid were studied in [2, 3]. When solving the problem by the Hamilton-Ostrogradsky variational principle, a system of equations for studying free vibrations of an inhomogeneous cylindrical shell being in dynamic contact with moving liquid and reinforced with rods, was structured.

Note that vibrations of a homogeneous cylindrical shell stiffened with anisotropic bars, and ideal liquid were studied in [4]. In the paper [5], free vibrations of an orthotropic, laterally stiffened, ideal fluid-filled cylindrical shell inhomogeneous in thickness and in circumferential direction is studied. Using the Ostrogradsky-Hamilton variational principle, the systems of equations of the motion of an orthotropic, ideal fluid filled cylindrical shell stiffened in thickness and circumference, are constructed.

In order to calculate inhomogeneity of the shell material in thickness and circumference, it is accepted that the young modulus and the density of the material of the shell are the functions of normal and circumferential coordinates. Frequency equations are constructed and free vibrations of an orthotropic, ideal fluid-filled, laterally stiffened cylindrical shell inhomogeneous in thickness and in circumference are numerically implemented. The characteristically dependence curves were constructed. In the paper [6], a problem of parametric vibration of an external elastic medium-contacting, longitudinally stiffened orthotropic cylindrical shell under the action of inner pressure in the geometrically nonlinear statement was solved by means of the variational principle.

2. PROBLEM STATEMENT

We get expressions of motion and boundary conditions for a orthotropic cylindrical shell filled with viscous liquid based on the Ostrogradsky-Hamilton principle. Since the system under consideration consists of cylindrical circular shells with longitudinal stiffened elements and viscous fluid (Figure 7a, 7b, 7c), we can write the total energy of the system in the form:

$$\Pi = G + K + \sum_{i=1}^{k_1} H_i + \sum_{j=1}^{k_2} H_j + A \tag{1}$$

where, G is a potential, K is a kinetic energy of the cylindrical shell, $\sum_{j=1}^{k_1} H_j$ is total energy of longitudinal,

$\sum_{j=1}^{k_2} H_j$ of transversal ribs used in stiffening, A is a work done by the external forces and takes into account influence of viscous fluid when the points of the cylindrical shell are displaced, k_1 is the amount of longitudinal ribs, k_2 is the amount of transverse ribs. The formulas to calculate these quantities are in the papers [3, 7].

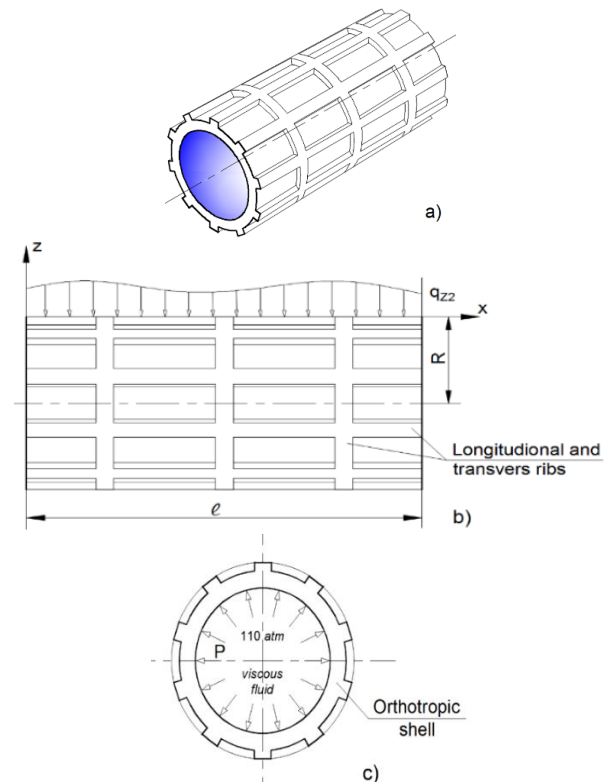

Figures 7. (a), (b), (c) - Construction under the action of radial load in dynamic interaction with viscous fluid

Intensity of load q_x, q_y, q_{z1} acting on the shell as viewed from viscous fluid is determined from the Navier-Stocks linearized equation [8]. To the expressions (1) we add contact and boundary conditions.

Considering that the edges of the shell are highly connected, i.e., for $x = 0$ and $x = l$

$$N_x = 0; M_x = 0; w = 0; \tilde{g} = 0 \tag{2}$$

where, N_x, M_x, \tilde{g}, w are longitudinal forces, bending moment, circumferential and normal components of displacements of shell points, respectively

At the points of the internal surface of the shell there will be $\left(r = R - \frac{h}{2} \right)$.

$$g_x = \frac{\partial u}{\partial t}, g_\theta = \frac{\partial \tilde{g}}{\partial t}, g_r = \frac{\partial w}{\partial t} \tag{3}$$

$$q_x = -\sigma_{rx}, q_\theta = -\sigma_{r\theta}, q_{z1} = -p \tag{4}$$

where, $\vec{g}(g_x, g_r, g_\theta)$ is the vector of velocity of an arbitrary point of the fluid, p is pressure at arbitrary

point of the fluid, q_x, q_y, q_{z1} are forces acting on the shell as viewed from viscous fluid $\sigma_{rx}, \sigma_{r\theta}$ are viscous forces [1].

The equation of motion of a viscous fluid-contacting, stiffened construction on the basis of Ostrogradsky-Hamilton principle of stationarity of actions:

$$\delta W = 0 \tag{5}$$

where, $W = \int_{t'}^{t''} \Pi dt$ is Hamilton's action, t' and t'' are the taken arbitrary moments of time [10].

3. PROBLEM SOLUTION

Let's take non-linear parametric vibrations of a cylindrical shell under the influence of radial force $q_{z2} = \tilde{q}_0 + \tilde{q}_1 \sin \omega_1 t$, where, \tilde{q}_0 is a principal load, \tilde{q}_1 is the amplitude of the load, ω_1 is frequency of pressure change in the viscous fluid-filled shell.

For describing the motion of fluid, we use the Navier-Stocks linearized equation for viscous incompressible fluid [8]:

$$\rho_m \frac{\partial \vec{g}}{\partial t} = -\text{grad} p + \frac{1}{3} \text{graddiv} \vec{g} + \bar{\mu} \nabla^2 \vec{g} \tag{6}$$

We represent the solution of the Navier-Stocks equation by a scalar potential φ and vector potential $\vec{\psi}$ in the form

$$\vec{g} = \text{grad} \varphi + \text{rot} \vec{\psi} \tag{7}$$

Substituting (7) in (6), we obtain:

$$\rho_m \frac{\partial (\text{grad} \varphi + \text{rot} \vec{\psi})}{\partial t} = -\text{grad} p + \frac{1}{3} \mu \text{graddiv} \vec{g} + \bar{\mu} \Delta \vec{g} \tag{8}$$

From (7) we easily get:

$$\text{div} \vec{g} = \Delta \varphi; \text{graddiv} \vec{g} = \text{grad} \Delta \varphi$$

Using the vector identity $\text{rotrot} \vec{g} = \text{graddiv} \vec{g} - \Delta \vec{g}$ we can write:

$$\Delta \vec{g} = \text{graddiv} \vec{g} - \text{rotrot} \vec{g} = \text{grad} \Delta \varphi - \text{rotrot} \vec{g}$$

Using (7), we find:

$$\begin{aligned} \text{rotrot} \vec{g} &= \text{rotrot} (\text{grad} \varphi + \text{rot} \vec{\psi}) = \\ &= \text{rotrotgrad} \varphi + \text{rot} (\text{rotrot} \vec{\psi}) = -\text{rot} \Delta \vec{\psi} \\ \text{graddiv} \vec{g} &= \text{grad} (\Delta \varphi). \end{aligned}$$

Substituting these relations in the equation of motion (8), we find:

$$\begin{aligned} \rho_m \frac{\partial}{\partial t} (\text{grad} \varphi) + \text{grad} p - \frac{4}{3} \bar{\mu} \text{grad} \Delta \varphi - \\ - \bar{\mu} \text{rot} \Delta \vec{\psi} + \rho_m \frac{\partial}{\partial t} \text{rot} \vec{\psi} = 0 \end{aligned}$$

or

$$\begin{aligned} \text{grad} \left(\rho_m \frac{\partial \varphi}{\partial t} + p - \frac{4}{3} \bar{\mu} \Delta \varphi \right) + \\ + \text{rot} \left(-\bar{\mu} \Delta \vec{\psi} + \rho_m \frac{\partial \vec{\psi}}{\partial t} \right) = 0 \end{aligned}$$

This equation will be satisfied if we assume.

$$\rho_m \frac{\partial \varphi}{\partial t} + p - \frac{4}{3} \bar{\mu} \Delta \varphi = 0 \tag{9}$$

$$-\bar{\mu} \Delta \vec{\psi} + \rho_m \frac{\partial \vec{\psi}}{\partial t} = 0 \tag{10}$$

Thus, we can get a particular solution of Equation (6) based on particular solution (9) and (10). It is seen from (9) and (10) that for finding the potentials φ and $\vec{\psi}$ one needs to know pressure p and density ρ_m of the fluid. We illustrate what has been said on an example when fluid is viscous Newtonian. In this case to the system of linearized Navier-Stocks Equations (6) that contains five unknowns, three velocity components g_x, g_r, g_θ , pressure p and density ρ_m we add a discontinuity equation $\frac{\partial \rho}{\partial t} + \rho_m \text{div} \vec{g} = 0$ and a formula of the form $\frac{\partial p}{\partial \rho} = a_*^2$ closing the system of equations. In the monograph [1] after some transformations the following linearized wave equation is obtained:

$$\frac{1}{a_*^2} \frac{\partial^2 p}{\partial t^2} = \nabla^2 \left(p + \frac{4\bar{\mu}}{3\rho_m a_*^2} \frac{\partial p}{\partial t} \right) \tag{11}$$

The solution of the equation (11) is of the form

$$p = (p_0 J_n(\lambda r) + c_0 Y_n(\lambda r)) \exp i(kx + n\theta + \omega t) \tag{12}$$

where, $\lambda = \sqrt{\frac{\omega^2}{a_*^2} \left(1 + i \frac{4\bar{\mu}\omega}{3\rho_m a_*^2} \right) - k^2}$, J_n, Y_n

are n th order Bessel functions parameters, n is the number of waves along circumference, k is a wave number or a constant propagated phase, $k = \frac{m\pi}{L}$, m is the amount of longitudinal waves in the shell, the quantity ω characterizes cyclic frequency of the wave, $\bar{\mu}$ is dynamical viscosity factor, ρ_m is density of the fluid in unperturbed state, a_* is velocity of propagation of small perturbations in fluid, p_0, c_0 are constants.

Considering the function p to be bounded for $r = 0$, we find $c_0 = 0$, and then finally

$$p = p_0 J_n(\lambda r) \exp i(kx + n\theta + \omega t) \tag{13}$$

From (9), for finding φ we get the equation

$$\Delta \varphi - \frac{3\rho_m}{4\bar{\mu}} \frac{\partial \varphi}{\partial t} = p_0 J_n(\lambda r) \exp i(kx + n\theta + \omega t) \tag{14}$$

The solution of the homogeneous Equation (14) is of the form:

$$\varphi = C_1 I_n(\tilde{k}r) + C_2 K_n(\tilde{k}r)$$

where, $\tilde{k} = \sqrt{k^2 + \frac{3i\omega\rho_m}{4\bar{\mu}}}$, $I_n(\tilde{k}r), K_n(\tilde{k}r)$ are order n th

order Bessel functions of first and second kind, respectively, C_1, C_2 are constants. By means of the method of variation constants, we can write the solution of the equation in the form

$$\varphi(r) = p_0 f(r) + \mu_1 I_n(\tilde{k}r) \tag{15}$$

where,

$$\Delta(r) = I_n(\tilde{k}r)K'(\tilde{k}r) - I_n'(\tilde{k}r)K_n(\tilde{k}r)$$

$$f(r) = -I_n(\tilde{k}r) \int_r^R \Delta^{-1}(\xi) J_n(\lambda\xi) K_n(\tilde{k}\xi) d\xi +$$

$$+ K_n(\tilde{k}r) \int_0^r \Delta^{-1}(\xi) J_n(\lambda\xi) I_n(\tilde{k}\xi) d\xi$$

The equation with respect to the components of the vector $\vec{\psi}(\psi_1, \psi_2, \psi_3)$ has the form

$$\overrightarrow{\Delta\psi} = \frac{\rho_m}{\bar{\mu}} \frac{\partial \vec{\psi}}{\partial t}$$

or

$$\psi_i''(r) + \frac{1}{r} \psi_i'(r) - \left(k^2 + \frac{i\omega\rho_m}{\bar{\mu}} + \frac{n^2}{r^2} \right) \psi_i(r) = 0 \tag{16}$$

The solution of the Equation (16) corresponding to the problem under consideration is of the form:

$$\psi_1 = \mu_2 J_n(qr); \psi_2 = \mu_3 J_n(qr)$$

$$\psi_3 = \mu_4 J_n(qr) \tag{17}$$

$$\text{where, } q = \sqrt{k^2 + \frac{i\omega}{\bar{\mu}}}$$

Using (6), (11) and (13), for the velocity vector components we obtain:

$$v_x = \left[-\frac{k\omega}{\rho_m a_*^2} p_0 f(r) + ikJ_n(kr)\mu_1 + \right. \tag{18}$$

$$\left. + inJ_n(qr)\mu_4 - qJ_n'(qr)\mu_3 \right] \times \exp i(kx + n\theta + \omega t)$$

$$v_\theta = \left[-\frac{n\omega}{\rho_m a_*^2} p_0 f(r) + inJ_n(kr)\mu_1 + \right.$$

$$\left. + ikJ_n(qr)\mu_4 - qJ_n'(qr)\mu_3 \right] \times \exp i(kx + n\theta + \omega t)$$

$$v_r = \left[\frac{i\omega}{\rho_m a_*^2} p_0 f'(r) + kJ_n'(kr)\mu_1 + \right.$$

$$\left. + ikJ_n(qr)\mu_3 - inJ_n(qr)\mu_2 \right] \times \exp i(kx + n\theta + \omega t)$$

By means of the viscosity force formula [8], we find:

$$\bar{\mu} \left[-\frac{2k\omega}{\rho_m a_*^2} f'(r) p_0 + 2ik^2 J_n'(kr)\mu_1 + \right.$$

$$\left. + nkJ_n(qr)\mu_2 - (k^2 J_n(qr) - J_n''(qr)) \right] \mu_3 +$$

$$+ inqJ_n'(qr)\mu_4 \exp i(kx + n\theta + \omega t)$$

$$\sigma_{r\theta} = \bar{\mu} \left[-\frac{2n\omega}{R\rho_m a_*^2} f'(r) p_0 + \frac{2ink}{R} J_n'(kr)\mu_1 + \right.$$

$$\left. + (n^2 J_n(qr) - q^2 + J_n''(qr)) \mu_2 - nkJ_n(qr)\mu_3 + \right. \tag{19}$$

$$\left. + ikqJ_n'(qr)\mu_4 \right] \exp i(kx + n\theta + \omega t)$$

$$\sigma_{rr} = p_0 J_n(\lambda r) \exp i(kx + n\theta + \omega t)$$

Using contact conditions (4) and expressions (19), we find the forces q_x, q_y, q_{z1} acting on the shell as viewed from viscous fluid

$$q_x = \bar{\mu} \left[-\frac{2k\omega}{\rho_m a_*^2} f'(R) p_0 + 2ik^2 J_n'(kR)\mu_1 + \right.$$

$$\left. + nkJ_n(qR)\mu_2 - (k^2 J_n(qR) - J_n''(qR)) \right] \mu_3 +$$

$$+ inqJ_n'(qR)\mu_4 \exp i(kx + n\theta + \omega t)$$

$$q_{z1} = p_0 J_n(\lambda R) \exp i(kx + n\theta + \omega t) \tag{20}$$

$$q_y = \bar{\mu} \left[-\frac{2n\omega}{R\rho_m a_*^2} f'(R) p_0 + \frac{2ink}{R} J_n'(kR)\mu_1 + \right.$$

$$\left. + (n^2 J_n(qR) - q^2 J_n''(qR)) \mu_2 - \right.$$

$$\left. - nkJ_n(qR)\mu_3 + ikqJ_n'(qR)\mu_4 \right] \times \exp i(kx + n\theta + \omega t)$$

We will look for the displacement of the shell points in the form:

$$u = -\frac{i}{\omega} \left[-\frac{k\omega}{\rho_m a_*^2} p_0 f(R) + ikJ_n'(kR)\mu_1 + \right.$$

$$\left. + inJ_n(qR)\mu_4 - qJ_n'(qR)\mu_3 \right] \times \exp i(kx + n\theta + \omega t)$$

$$g = -\frac{i}{\omega} \left[-\frac{n\omega}{\rho_m a_*^2} p_0 f(R) + inJ_n(kR)\mu_1 \right] +$$

$$+ ikJ_n(qR)\mu_4 - qJ_n'(qR)\mu_2 \times \exp i(kx + n\theta + \omega t)$$

$$w = -\frac{i}{\omega} \left[\frac{i\omega}{\rho_m a_*^2} p_0 f'(R) + kJ_n'(kR)\mu_1 + \right.$$

$$\left. + ikJ_n(qR)\mu_3 - inJ_n(qR)\mu_2 \right] \times \exp i(kx + n\theta + \omega t) \tag{21}$$

Under such solutions, conditions (3) are fulfilled automatically. Using formula (21) we can calculate the work A done by the external forces and taking into account the influence of viscous fluid when the points of cylindrical shells are displaced, and total energy of longitudinal and transverse ribs. Let us consider the solution of the problem in the first approximation and with respect to coordinate and time functions. Considering (21) in functional Π and in respect that $x_1 = 0, x_2 = l, y_1 = 0, y_2 = 2\pi, t' = 0, t'' = \frac{\pi}{\omega}$.

Let's integrate these expressions with respect to x, y, t and get the function W with the quantities $\mu_1, \mu_2, \mu_3, \mu_4, p_0$.

The fixed magnitude of the expression is defined by the next nonlinear system of equations:

$$\frac{\partial W}{\partial \mu_i} = 0; \frac{\partial W}{\partial p_0} = 0 \quad (i = 1, 2, 3, 4) \tag{22}$$

4. CONCLUSIONS

The system (22) was solved for the following values of input data [9].

The results of calculations are on Figure 8 and 9. The dependences of ratios of nonlinear frequency to the linear one on deflection in the case of vibrations of a fluid-shell under different values of ratios E_1/E_2 of the shell material and for the fixed values of \tilde{E}_i are given in Figure 8.

$$R = 16 \times 10^{-2} \text{ m}; h = 45 \times 10^{-5} \text{ m}; l = 8 \times 10^{-1} \text{ m};$$

$$\rho_0 = \rho_i 7800 \frac{\text{kg}}{\text{m}^3}; \tilde{E} = 6.67 \times 10^9 \text{ Pa}; \nu_1 = 0.11;$$

$$\nu_2 = 0.19; |h_i| = 0.1375 \times 10^{-1} R; k_1 = 10;$$

$$m = 8; \frac{F_i}{2\pi R h} = 0.1591 \times 10^{-1};$$

$$\frac{J_{yi}}{2\pi R^3 h} = 0.8289 \times 10^{-6};$$

$$\frac{J_{zi}}{2\pi R^3 h} = 0.13 \times 10^{-6}; \frac{J_{kpi}}{2\pi R^3 h} = 0.5305 \times 10^{-6};$$

$$h_j = 1.39 \text{ mm}; \bar{\mu} = 0.355;$$

$$F_j = 5.75 \text{ mm}^2; \frac{J_{kpi}}{2\pi R^3 h} = 0.5305 \times 10^{-6};$$

$$J_{xj} = 19.9 \text{ mm}^4; \rho_j = 0.26 \times 10^4 \text{ Nsec}^2/\text{m}^2$$

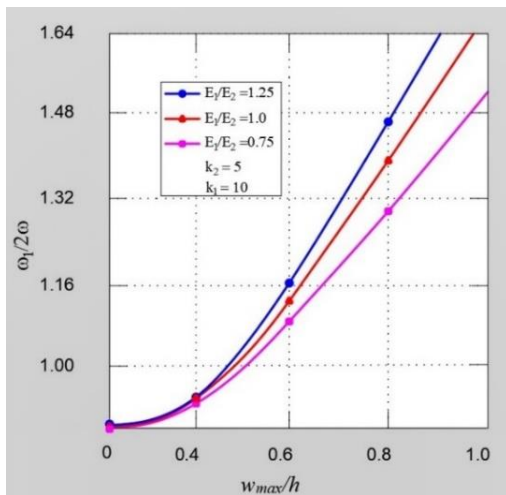

Figure 8. Dependence of frequency on deflection

It is seen that with increasing the ratios E_1 / E_2 and shell deflection, nonlinear frequencies of the vibrations of the system increase. The dependences of ratios of nonlinear part to the linear one on the number of longitudinal bars are given in Figure 9. It's obviously from the graph that rising the number of longitudinal ribs, at first nonlinear frequencies of vibrations increase, and then attaining maximum they began to decrease. It is explained by the fact that at first by increasing the number of longitudinal ribs the rigidity of the system increases, and with a further increase in the number of longitudinal ribs, the inertia prevails over rigidity.

1. With the increase in the ratio of the modulus of the elasticity of the material of the shell, the frequencies of nonlinear vibrations of the system increase.
2. With the increase of the flexure of the shell, the frequencies of nonlinear vibrations of the system increase.
3. With an increase in the number of longitudinal ribs, at first the nonlinear vibration frequencies increase, and then, reaching a maximum, they begin to decrease.

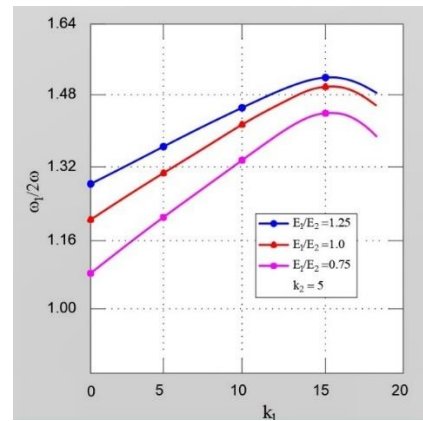

Figure 9. Dependence of frequency on the number of longitudinal bars

REFERENCES

- [1] A.Yu. Blinkova, Yu.A. Blinkov, L.I. Mogilevich, "Nonlinear Waves in Co-Axial Cylindrical Shells Containing Viscous Fluid between them, taking into account the Scattering of Energy", Computational Continuum Mechanics, Vol. 6, No. 3, pp. 336-345, 2013.
- [2] R.N. Agayev, "Vibrations of Heterogeneous Cylindrical Shell Stiffened with Rings and Dynamically Contacting with Flowing Fluid", International Journal on Technical and Physical Problems of Engineering (IJTPE), Issue 43, Vol. 12, No. 2, pp. 83-87, June 2020.
- [3] R.N. Agayev, "Vibrations of an Inhomogeneous Cylindrical Shell Dynamically Interacting with Motive Fluid and Stiffened with Rings", International Journal on Technical and Physical Problems of Engineering (IJTPE), Issue 42, Vol. 12, No. 1, pp. 31-34, March 2020.
- [4] F.S. Latifov, Z.M. Badirov, "Oscillations of Anisotropic Homogeneous Longitudinally Supported Cylindrical Shell with a Liquid", The 14th International Conference on Technical and Physical Problems of Electrical Engineering (ICTPE-2018), Nakhchivan, Azerbaijan, pp. 172-176, 15-17, October 2018.
- [5] Z.M. Badirov, "Vibrations of an Anisotropic Laterally Stiffened Fluid Filled Cylindrical Shell Inhomogeneous in Thickness and Circumference", International Journal on Technical and Physical Problems of Engineering (IJTPE), Issue 42, Vol. 12, No. 1, pp. 73-77, March 2020.
- [6] F.S. Latifov, M.A. Mekhtiev, "Nonlinear Parametric Vibrations of a Liquid-Filled, Longitudinally Stiffened Orthotropic Cylindrical Shell", Applied Mechanics and Technical Physics, Vol. 59, No. 4, pp. 195-203, 2018.
- [7] I.Y. Amiro, V.A. Zarutskiy, "Theory of Edged Shells- Methods for Calculating Shells", Naukova Dumka, p. 367, 1980.
- [8] A.S. Volmir, "Shells in Liquid and Gas Flow, Aeroelasticity Problem", M. Sciences, p. 416, 1976.
- [9] R.A. Iskandarov, J.M. Tabatabaei, "Vibrations of Fluid-Filled Inhomogeneous Cylindrical Shells Strengthened With laterals Ribs", International Journal on Technical and Physical Problems of Engineering (IJTPE), Issue 42, Vol. 12, No. 1, pp. 121-125, March 2020.
- [10] R.A. Iskandarov, "Stability of Reinforced and Damaged Structures in the Environment", LAP LAMBERT Academic Publishing, Germany, p. 281, 2017.

BIOGRAPHIES



Aynur Ilyas Khudiyeva was born in Sadakhlo, Georgia on October 8, 1985. She graduated from Baku State University, Baku, Azerbaijan, in Mathematics and also received bachelor degree in 2007 and also master degree in 2010. In 2016 she received the Ph.D. degree in Mathematics from Institute Mathematics and also Mechanics, Baku, Azerbaijan. She is author of monograph in Germany, 4 patents and also more than 15 articles and also publications. Since 2013 to the present, she was been working as senior lecturer in Azerbaijan University of Architecture and also Construction.



Maarif Zabit Yusifov was born in Tovuz, Azerbaijan in 1976. In 1998 he graduated from Azerbaijan University of Civil Engineers with bachelor's degree and in 2000 master's degree from Azerbaijan University of Architecture and construction with honors. In 2000 he began his pedagogical activity at "Department of Operation and Reconstruction of Buildings and Facilities" of the University of Azerbaijan and is currently working as an associate professor. In 2017 he received the degree of doctor of philosophy in technical sciences. At the same time, he worked as a group Manager-Engineer in the design of many buildings and residential complexes at the "Project Institute of Azerbaijan University of Architecture and Construction" LLC. He is the author of 1 textbook, 3 subject programs and about 30 scientific articles.